



966M

Wheel Loader

Technical Specifications

Engine

Engine Model	Cat® C9.3
Maximum Gross Power (1,800 rpm)	
SAE J1995	232 kW (315 hp metric)
Maximum Power (1,800 rpm)	
ISO 14396	229 kW (311 hp metric)
Maximum Net Power (1,700 rpm)	
ISO 9249	206 kW (280 hp metric)
Peak Gross Torque (1,200 rpm)	
SAE J1995	1599 N·m
Peak Torque (1,200 rpm)	
ISO 14396	1581 N·m
Maximum Net Torque (1,000 rpm)	
ISO 9249	1527 N·m
Bore	115 mm
Stroke	149 mm
Displacement	9.3 L

- Meets either EU Stage V or EU Stage IV* emission standards.
*Stage IV engines comply with the transition provisions of the EU non-road emission regulation
- The power ratings apply at the stated speed when tested under the reference conditions for the specified standards.
- The net power advertised is the power available at the flywheel when the engine is equipped with fan, alternator, air cleaner and aftertreatment.
- The gross power advertised is with the fan at maximum speed.

Buckets

Bucket Capacities	3.20-7.40 m ³
-------------------	--------------------------

Weight

Operating Weight	23 220 kg
------------------	-----------

- Weight based on a machine configuration with Michelin 26.5R25 XHA2 L3 radial tires, full fluids, operator, standard counterweight, cold start, roading fenders, Product Link™, manual diff lock/open axles (front/rear), power train guard, secondary steering, sound suppression and a 4.2 m³ general purpose bucket with bolt-on cutting edges.

Operating Specifications

Static Tipping Load – Full 37° Turn

With Tire Deflection	14 668 kg
No Tire Deflection	15 822 kg
Breakout Force	173 kN

- For a machine configuration as defined under “Weight.”
- Full compliance to ISO 14397-1:2007 Sections 1 thru 6, which requires 2% verification between calculations and testing.

Transmission

Forward 1	6.5 km/h
Forward 2	13.0 km/h
Forward 3	23.5 km/h
Forward 4	39.5 km/h
Reverse 1	7.1 km/h
Reverse 2	14.4 km/h
Reverse 3	25.9 km/h
Reverse 4	39.5 km/h

- Maximum travel speed in standard vehicle with empty bucket and standard L3 tires with 826 mm roll radius.

966M Wheel Loader Specifications

Brakes

Brakes	Brakes meet ISO 3450:2011 standards
--------	-------------------------------------

Hydraulic System

Implement Pump Type	Variable Displacement Piston
Implement System	
Maximum Pump Output (2,200 rpm)	360 L/min
Maximum Operating Pressure	31 000 kPa
Maximum Flow – Optional 3 rd /4 th Function	240 L/min
Maximum Pressure – Optional 3 rd /4 th Function	21 780 kPa
Hydraulic Cycle Time with Rated Payload	
Raise from Carry Position	6.1 Sec.
Dump, at Maximum Raise	1.4 Sec.
Lower, Empty, Float Down	2.6 Sec.
Total	10.1 Sec.

Axles

Front	Fixed
Rear	Oscillating ± 13 degrees
Maximum Single-Wheel Rise and Fall	502 mm

Cab

ROPS/FOPS	ROPS/FOPS meet ISO 3471:2008 and ISO 3449:2005 Level II standards
-----------	---

Sound

The sound values indicated below are for specific operating conditions only. Machine and operator sound levels will vary at different engine and/or cooling fan speeds. Hearing protection may be needed when the machine is operated with a cabin that is not properly maintained, or when the doors and/or windows are open for extended periods or in a noisy environment.

Operator Sound Pressure Level (ISO 6396:2008)	69 dB(A)*
Exterior Sound Power Level (ISO 6395:2008) European Union Directive “2000/14/EC” as amended by “2005/88/EC”	108 dB(A)*
Exterior Sound Pressure Level (SAE J88:2013)	76 dB(A)**

*For a standard machine configuration, measured according to the procedures specified with the cooling fan speed set at 70% of maximum value.

**For a standard machine configuration, measured according to the procedures specified. The measurement was conducted under the following conditions: distance of 15 m, moving forward in second gear ratio with the cooling fan speed set at maximum value.

Service Refill Capacities

Fuel Tank	302 L
DEF Tank*	16.8 L
Cooling System	71.6 L
Crankcase	24.5 L
Transmission	58.5 L
Differentials and Final Drives – Front	57 L
Differentials and Final Drives – Rear	57 L
Hydraulic Tank	125 L

*DEF must meet the requirements outlined in ISO 22241-1.

Air Conditioning System

The air conditioning system on this machine contains the fluorinated greenhouse gas refrigerant R134a (Global Warming Potential = 1430). The system contains 1.6 kg of refrigerant which has a CO₂ equivalent 2.288 metric tonne.

966M Wheel Loader Specifications

Dimensions

All dimensions are approximate.

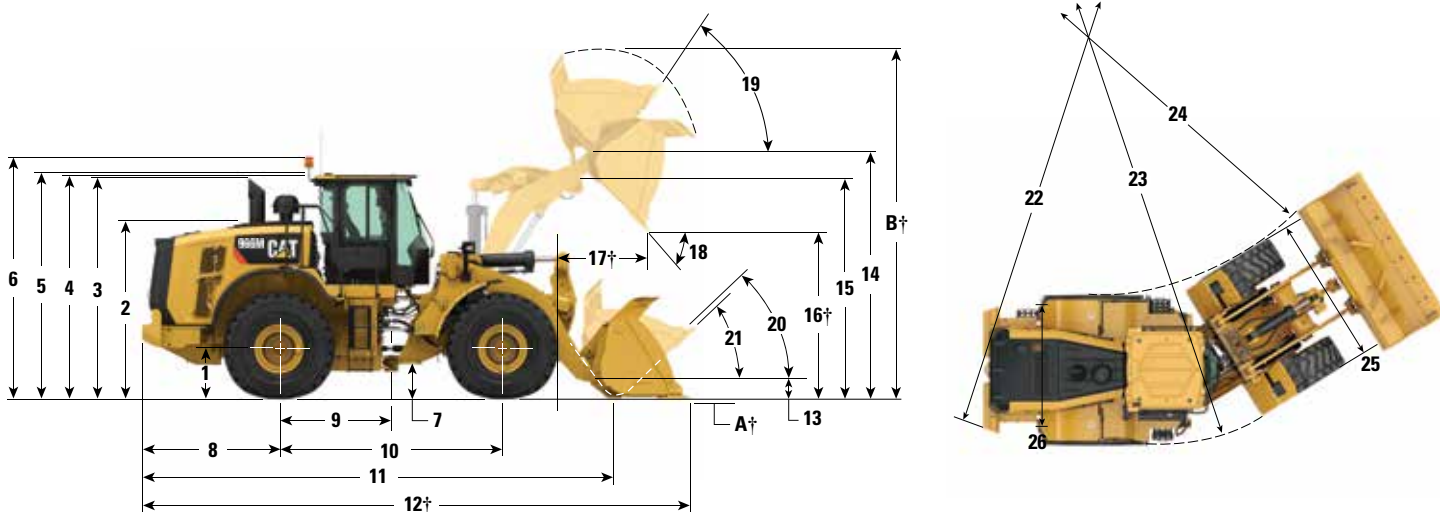

	Standard Lift	High Lift
1 Height to Axle Centerline	799 mm	799 mm
2 Height to Top of Hood	2818 mm	2818 mm
3 Height to Top of Exhaust Pipe	3522 mm	3522 mm
4 Height to Top of ROPS	3587 mm	3587 mm
5 Height to Top of Product Link Antenna	3636 mm	3636 mm
6 Height to Top of Warning Beacon	3859 mm	3859 mm
7 Ground Clearance	434 mm	434 mm
8 Center Line of Rear Axle to Edge of Counterweight	2180 mm	2500 mm
9 Center Line of Rear Axle to Hitch	1775 mm	1775 mm
10 Wheelbase	3550 mm	3550 mm
11 Overall Length (without bucket)	7289 mm	8109 mm
12 Shipping Length (with bucket level on ground)*†	8750 mm	9570 mm
13 Hinge Pin Height at Carry Height	630 mm	778 mm
14 Hinge Pin Height at Max Lift	4235 mm	4793 mm
15 Lift Arm Clearance at Max Lift	3643 mm	4140 mm
16 Dump Clearance at Max Lift and 45° Discharge*†	2991 mm	3549 mm
17 Reach at Max Lift and 45° Discharge*†	1353 mm	1328 mm
18 Dump Angle at Max Lift and Dump (on stops)*	49 degrees	48 degrees
19 Rack Back at Max Lift*	62 degrees	71 degrees
20 Rack Back at Carry Height*	50 degrees	49 degrees
21 Rack Back at Ground*	42 degrees	39 degrees
22 Turning Radius to Counterweight	6804 mm	6804 mm
23 Turning Radius to Outside of Tires	6761 mm	6761 mm
24 Turning Radius to Inside of Tires	3853 mm	3853 mm
25 Max Width over Tires (unloaded)	2991 mm	2991 mm
Max Width over Tires (loaded)	3009 mm	3009 mm
26 Tread Width	2230 mm	2230 mm

*Standard and High Lift are with 4.2 m³ general purpose pin-on bucket with bolt-on cutting edges (see Operating Specifications for other buckets).

†Dimensions are listed in Operating Specification charts.

All height and tire related dimensions are with Michelin 26.5R25 XHA2 L3 tires (see Dimension changes – Tires Chart for other tires). “Width over Tires” dimensions are over the bulge and include growth.

966M Wheel Loader Specifications

Dimension Changes – Tires

Tire Brand	Michelin	Michelin	Michelin	Bridgestone	Bridgestone
Tire Size	26.5R25	26.5R25	26.5R25	26.5R25	26.5R25
Tread Type	L-4	L-5	L-5	L-3	L-4
Tread Pattern	XLDD1	XLDD2	XMINED2	VJT	VSNT
Width over Tires – Maximum (empty)*	2987 mm	2986 mm	2970 mm	2982 mm	2973 mm
Width over Tires – Maximum (loaded)*	3019 mm	3011 mm	2994 mm	3016 mm	2993 mm
Change in Vertical Dimensions (average of front and rear)	44 mm	39 mm	53 mm	15 mm	25 mm
Change in Horizontal Reach	-36 mm	-34 mm	-32 mm	-3 mm	-24 mm
Change in Clearance Circle (radius) to Outside of Tires	5 mm	1 mm	-7 mm	3 mm	8 mm
Change in Clearance Circle (radius) to Inside of Tires	-5 mm	-1 mm	7 mm	-3 mm	8 mm
Change in Operating Weight (without Ballast)	420 kg	716 kg	1068 kg	164 kg	624 kg
Change in Static Tipping Load – Straight	303 kg	517 kg	771 kg	118 kg	451 kg
Change in Static Tipping Load – Articulated	271 kg	461 kg	688 kg	106 kg	402 kg

Dimension Changes – Tires

Tire Brand	Bridgestone	Bridgestone	Flexport™	Flexport
Tire Size	26.5R25	775/65R29	70×14×28 (26.5×25)	70×14×28 (26.5×25)
Tread Type	L-5	L-3	—	—
Tread Pattern	VSDL	VTS	OTR	SMOOTH
Width over Tires – Maximum (empty)*	2874 mm	3080 mm	2955 mm	2896 mm
Width over Tires – Maximum (loaded)*	2900 mm	3101 mm	2972 mm	2915 mm
Change in Vertical Dimensions (average of front and rear)	50 mm	17 mm	59 mm	52 mm
Change in Horizontal Reach	-29 mm	-5 mm	-23 mm	-13 mm
Change in Clearance Circle (radius) to Outside of Tires	-54 mm	46 mm	-19 mm	-47 mm
Change in Clearance Circle (radius) to Inside of Tires	54 mm	-46 mm	19 mm	47 mm
Change in Operating Weight (without Ballast)	1136 kg	856 kg	3287 kg	3764 kg
Change in Static Tipping Load – Straight	821 kg	618 kg	2375 kg	2719 kg
Change in Static Tipping Load – Articulated	732 kg	551 kg	2118 kg	2425 kg

*Width over bulge and includes tire growth.

Note: Changes compared to:

– Michelin 26.5R25 XHA2 L3 radial tires.

966M Wheel Loader Specifications

Bucket Fill Factors and Selection Chart

The bucket size must be chosen based on the density of the material and on the expected fill factor. The Cat Performance Series Buckets with longer floor, larger bucket opening, increased repository angle, rounded side boards and integrated spill guard, demonstrate fill factors significantly higher than previous generation or non Cat buckets. The actual volume handled by the machine is thus often larger than the rated capacity.

Loose Material		Material Density	Fill Factor (%)*
Earth/Clay		1500-1700 kg/m ³	115
Sand and Gravel		1500-1700 kg/m ³	115
Aggregate:	25-76 mm	1600-1700 kg/m ³	110
	19 mm and smaller	1800 kg/m ³	105
Rock:	76 mm and larger	1600 kg/m ³	100

*As a % of ISO 7546 rated capacity.

Note: Fill Factors achieved will also depend on whether the product is washed or not washed.

Material Density		kg/m ³	700	800	900	1000	1100	1200	1300	1400	1500	1600	1700	1800	1900	2000	2100	2200	2300	2400	2500		
Standard Linkage	Pin-On	Rock	3.40 m ³											3.91 m ³								3.40 m ³	
		Material Handling	4.00 m ³											4.60 m ³									4.00 m ³
	4.20 m ³												4.83 m ³										4.20 m ³
	4.40 m ³											5.06 m ³											4.40 m ³
	QC	Material Handling	4.20 m ³										4.83 m ³										4.20 m ³
High Lift Linkage	Pin-On	Rock	3.40 m ³											3.91 m ³								3.40 m ³	
		Material Handling	4.00 m ³											4.60 m ³									4.00 m ³
	4.20 m ³												4.83 m ³										4.20 m ³
	4.40 m ³											5.06 m ³											4.40 m ³
	QC	Material Handling	4.20 m ³										4.83 m ³										4.20 m ³
Aggregate Handler Package	Pin-On	Light Material	7.10 m ³			8.17 m ³																7.10 m ³	
		Material Handling	4.40 m ³											5.06 m ³									4.40 m ³
	4.60 m ³												5.29 m ³										4.60 m ³
	4.80 m ³											5.52 m ³											4.80 m ³
	QC	Material Handling	4.40 m ³										5.06 m ³									4.40 m ³	

Material Density

Bucket Fill Factors

115% 110% 105% 100% 95%

Note: All buckets are showing Bolt-On Edges.

QC = Quick Coupler

966M Wheel Loader Specifications

Operating Specifications with Buckets

Machine		Standard Linkage						
Pin/Quick Coupler		Pin-On				Fusion™ QC	Universal QC	
Bucket Type		Material Handling		Material Handling Heavy Duty		Material Handling	Material Handling	
Edge Type		Bolt-On Cutting Edges	Teeth and Segments	Bolt-On Cutting Edges	FMT	Bolt-On Cutting Edges	Bolt-On Cutting Edges	High Lift Linkage Change**
Capacity – Rated	m ³	4.20	4.20	4.20	4.20	4.20	4.20	—
Capacity – Rated at 110% Fill Factor	m ³	4.62	4.62	4.62	4.62	4.62	4.62	—
Width	mm	3220	3271	3220	3201	3220	3220	—
16 † Dump Clearance at Maximum Lift and 45° Discharge	mm	2949	2787	2949	3001	2899	2787	559
17 † Reach at Maximum Lift and 45° Discharge	mm	1245	1372	1245	1236	1296	1498	-25
Reach at Level Lift Arm and Bucket Level	mm	2774	2978	2774	2731	2845	3067	404
A † Digging Depth	mm	124	124	124	94	124	60	-25
12 † Shipping Length (with Bucket)	mm	8721	8946	8721	8653	8792	8961	825
B † Overall Height with Bucket at Maximum Lift	mm	5901	5901	5901	5940	5943	6134	559
Loader Clearance Circle Radius with Bucket at Carry Position	mm	7504	7589	7504	7473	7519	7561	242
Static Tipping Load, Straight (With Tire Deflection)*	kg	16 580	16 398	16 465	16 155	15 919	14 950	55
Static Tipping Load, Straight (No Tire Deflection)*	kg	17 731	17 546	17 615	17 312	17 052	16 058	-32
Static Tipping Load, Articulated (With Tire Deflection)*	kg	14 605	14 421	14 489	14 162	13 969	13 078	-128
Static Tipping Load, Articulated (No Tire Deflection)*	kg	15 740	15 555	15 623	15 307	15 091	14 177	-187
Breakout Force***	kN	177	175	176	180	167	141	-15
Operating Weight*	kg	23 217	23 355	23 336	23 706	23 678	23 889	1612

*Static tipping loads and operating weights are based on a machine configuration with Michelin 26.5R25 XHA2 L3 radial tires, full fluids, operator, standard counterweight, cold start, roading fenders, Product Link, manual diff lock/open axles (front/rear), power train guard, secondary steering and sound suppression.

**Maximum values.

***Measured 102 mm behind tip of cutting edge with bucket hinge pin as pivot in accordance with SAE J732C.

(With Tire Deflection) Full compliance to ISO 14397-1:2007 Sections 1 thru 6, which requires 2% verification between calculations and testing.

(No Tire Deflection) Compliance to ISO 14397-1:2007 Sections 1 thru 5.

†Illustration shown with Dimension charts.

FMT = Flush Mounted Teeth

QC = Quick Coupler

Additional buckets are available and offerings vary by region. Consult your local Cat dealer for further details.

966M Wheel Loader Specifications

Operating Specifications with Buckets – Aggregate Handler

Machine		Aggregate Handler***					
Pin/Quick Coupler		Pin-On				Fusion QC	Universal QC
Bucket Type		Material Handling		Light Material		Material Handling	Material Handling
Edge Type		Bolt-On Cutting Edges	Bolt-On Cutting Edges	Bolt-On Cutting Edges	Bolt-On Cutting Edges	Bolt-On Cutting Edges	Bolt-On Cutting Edges
Capacity – Rated	m ³	4.40	4.60	4.80	7.10	4.40	4.40
Capacity – Rated at 110% Fill Factor	m ³	4.84	5.06	5.28	7.81	4.84	4.62
Width	mm	3220	3220	3220	3447	3220	3220
16† Dump Clearance at Maximum Lift and 45° Discharge	mm	2921	2893	2865	2625	2872	2841
17† Reach at Maximum Lift and 45° Discharge	mm	1274	1302	1330	1548	1323	1622
Reach at Level Lift Arm and Bucket Level	mm	2814	2854	2894	3217	2884	3104
A† Digging Depth	mm	124	124	124	140	124	60
12† Shipping Length (with Bucket)	mm	8809	8849	8889	9224	8879	9046
B† Overall Height with Bucket at Maximum Lift	mm	5931	5982	6023	6071	5973	6183
Loader Clearance Circle Radius with Bucket at Carry Position	mm	7514	7524	7534	7728	7529	7571
Static Tipping Load, Straight (With Tire Deflection)*	kg	18 077	18 013	17 938	17 508	17 397	16 505
Static Tipping Load, Straight (No Tire Deflection)*	kg	19 386	19 329	19 260	18 881	18 687	17 789
Static Tipping Load, Articulated (With Tire Deflection)*	kg	15 861	15 799	15 726	15 301	15 209	14 390
Static Tipping Load, Articulated (No Tire Deflection)*	kg	17 158	17 103	17 036	16 663	16 492	15 670
Breakout Force**	kN	171	166	161	129	162	138
Operating Weight*	kg	23 965	24 000	24 046	24 223	24 427	24 592

*Static tipping loads and operating weights are based on a machine configuration with Michelin 26.5R25 XHA2 L3 radial tires, full fluids, operator, aggregate counterweight, cold start, roading fenders, Product Link, manual diff lock/open axles (front/rear), power train guard, secondary steering and sound suppression.

**Measure 102 mm behind tip of cutting edge with bucket hinge pin as pivot in accordance with SAE J732C. Specifications and ratings confirm to all applicable standards recommended by the Society of Automotive Engineers, including SAE Standard J732C governing loader ratings.

***Aggregate Handler Configurations are NOT compatible with L5 Tires, Teeth, Teeth and Segments, and Spade Nose Rock Bucket.

(With Tire Deflection) Full compliance to ISO 14397-1:2007 Sections 1 thru 6, which requires 2% verification between calculations and testing.

(No Tire Deflection) Compliance to ISO 14397-1:2007 Sections 1 thru 5.

†Illustration shown with Dimension charts.

QC = Quick Coupler

Additional buckets are available and offerings vary by region. Consult your local Cat dealer for further details.

966M Wheel Loader Specifications

Operating Specifications with High Dump Buckets

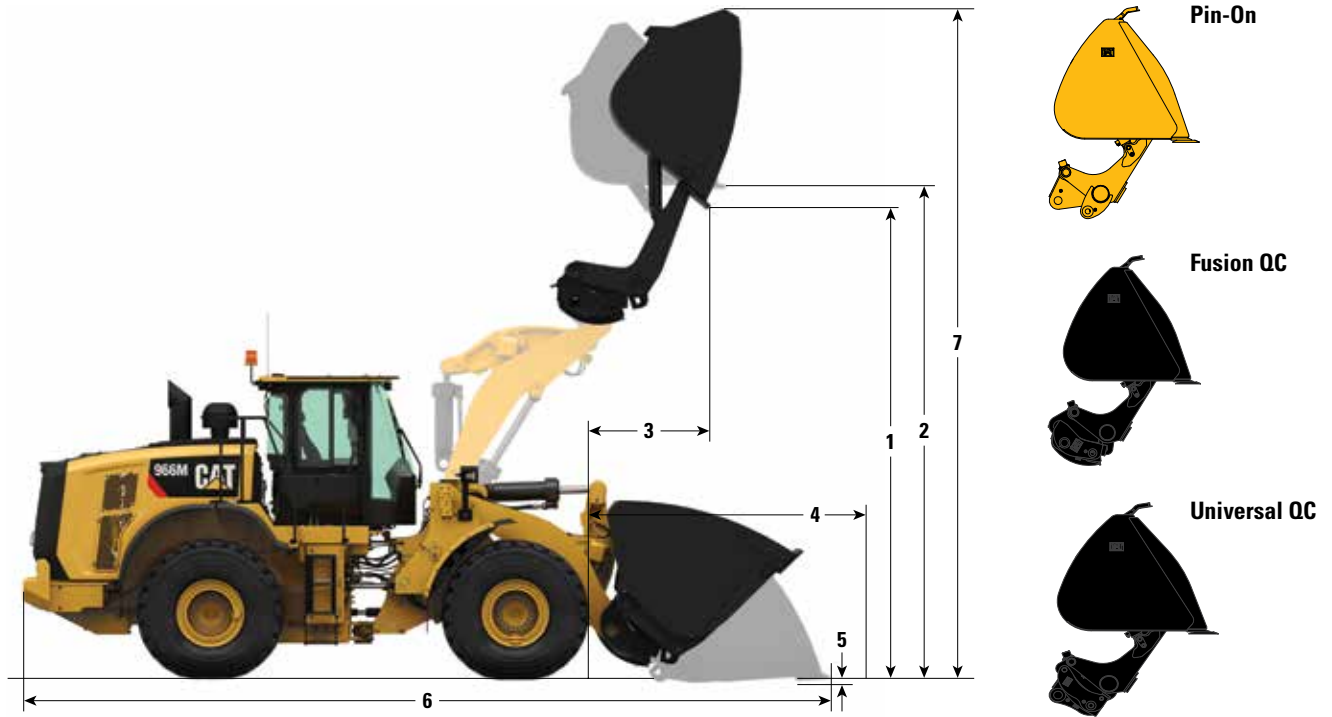

Interface		Pin-On	Fusion QC	Universal QC
Edge Type		Bolt-On Cutting Edges	Bolt-On Cutting Edges	Bolt-On Cutting Edges
Capacity – Rated	m ³	11.10	11.10	11.10
Capacity – Rated at 110% Fill Factor	m ³	12.20	12.20	12.20
Width	mm	3656	3656	3656
Nominal Material Density – 110% Fill Factor	kg/m ³	630	610	570
1 Dump Clearance at Maximum Lift, Maximum Rack, Bucket Rolled out to 45° Discharge	mm	4680	4698	4861
2 Clearance at Maximum Lift, Maximum Rack, Bucket Rolled out to Level	mm	5348	5366	5529
3 Reach at Maximum Lift, Maximum Rack, Bucket Rolled out to 45° Discharge	mm	1885	1894	1982
4 Reach at Level Lift Arm and Bucket Level	mm	3828	3848	4033
5 Digging Depth	mm	94	94	94
6 Overall Length	mm	9823	9843	10 028
7 Overall Height with Bucket at Maximum Height and Maximum Rack	mm	7483	7500	7663
Clearance Circle (Radius) with Bucket at Carry Position	mm	8023	7994	8049
Static Tipping Load, Straight (With Tire Deflection)*	kg	15 420	14 969	14 157
Static Tipping Load, Straight (No Tire Deflection)*	kg	16 762	16 300	15 441
Static Tipping Load, Articulated (With Tire Deflection)*	kg	13 288	12 845	12 106
Static Tipping Load, Articulated (No Tire Deflection)*	kg	14 645	14 191	13 407
Breakout Force	kN	93	92	82
Operating Weight*	kg	25 442	25 926	26 085

*Static tipping loads and operating weights are based on a machine configuration with Michelin 23.5R25 XHA2 L3 radial tires, full fluids, operator, auxiliary counterweight, cold start, roading fenders, Product Link, manual diff lock/open axles (front/rear), power train guard, secondary steering and sound suppression.

(With Tire Deflection) Full compliance to ISO 14397-1:2007 Sections 1 thru 6, which requires 2% verification between calculations and testing.

(No Tire Deflection) Compliance to ISO 14397-1:2007 Sections 1 thru 5.

QC = Quick Coupler

Additional high dump buckets are available and offerings vary by region. Consult your local Cat dealer for further details.

966M Wheel Loader Specifications

Operating Specifications with Pallet Fork

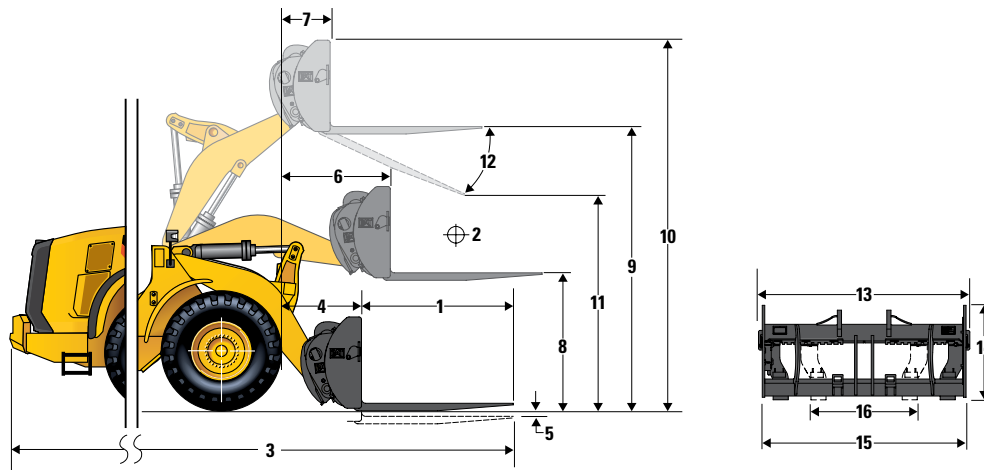

Interface	Standard Counterweight	
		Fusion QC
1 Tine Length	mm	1829
2 Load Center	mm	915
3 Maximum Overall Length	mm	9531
4 Reach with Forks at Ground Level	mm	1106
5 Ground to Top of Tine at Minimum Height and Fork Level	mm	-11
6 Reach with Arms Horizontal and Forks Level	mm	1704
7 Reach with Fork at Maximum Height	mm	836
8 Ground to Top of Tine with Arms Horizontal and Fork Level	mm	1955
9 Ground to Top of Tine at Maximum Height and Fork Level	mm	4039
10 Overall Height of Fork at Full Lift (Top of Carriage to Ground)	mm	5079
11 Clearance at Full Lift and Maximum Dump	mm	2292
12 Maximum Discharge Angle from Horizontal	degrees	51
13 Overall Carriage Width	mm	2528
14 Overall Carriage Height	mm	1130
15 Outside Tine Width (Maximum Spread)	mm	2178
16 Outside Tine Width (Minimum Spread)	mm	576
Tine Width (Single Tine)	mm	180.0
Tine Thickness	mm	90.0
Tine Capacity	kg	14 800
Static Tipping Load – Straight (Forks Level)*	kg	11 345
Static Tipping Load – Articulated (Forks Level)*	kg	10 013
Rated Load (SAE J1197 – 50% FTSTL)**	kg	5007
Rated Load (CEN EN 474-3 Rough Terrain – 60% FTSTL)**	kg	6008
Rated Load (CEN EN 474-3 Firm and Level Ground – 80% FTSTL)**	kg	7807
Operating Weight*	kg	22 683

*Static tipping loads and operating weights are based on L3 Michelin XHA tires, air conditioning, ride control, power train guard, full fluids, fuel tank, coolant, lubricants, and operator.

**The rated operating load for a loader equipped with a pallet fork is determined by: SAE J1197: 50% of full turn static tipping load or hydraulic limit. CEN EN 474-3: 60% of full turn static tipping load on rough terrain or hydraulic limit. CEN EN 474-3: 80% of full turn static tipping load on firm and level ground or hydraulic limit.

SAE – Society of Automotive Engineers. CEN – European Committee for Standardization. Refer to the Forks Product Bulletins for capacity load charts.

Additional forks are available and offerings vary by region. Consult your local Cat dealer for further details.

966M Wheel Loader Standard and Optional Equipment

Standard and Optional Equipment

Standard and optional equipment may vary. Consult your Cat dealer for details.

	Standard	Optional		Standard	Optional
POWER TRAIN			OPERATOR ENVIRONMENT		
Axles, ecology drains	✓		Air conditioner, heater, and defroster (auto temp and fan)	✓	
Axles, manually actuated differential lock front axle, open differential rear axle	✓		Beverage holders (2) with storage compartment for cell phone/MP3 player	✓	
Axles: automatic front/rear differential locks, axle oil cooler, extreme temperature seals, seal guards		✓	Bucket/work tool function lockout	✓	
Brake wear indicators	✓		Cab air filter	✓	
Brakes, full hydraulic enclosed wet-disc with Integrated Braking System (IBS)	✓		Cab, pressurized and sound suppressed (ROPS/FOPS)	✓	
Cat Clean Emissions Module (CEM) with Diesel Exhaust Fluid (DEF) tank and pump	✓		Cab tie-off	✓	
Economy mode (selectable)	✓		Cat seat cover, removable		✓
Engine, Cat C9.3 – meets Stage V or Stage IV emission standards	✓		Coat hook (2)	✓	
Fan, radiator, on demand	✓		Cover, HVAC metallic		✓
Fan, VPF (variable pitch fan), automatic and manual control		✓	Door, remote opening system		✓
Fuel priming pump (electric)	✓		EH controls, SAL (single axis lever) lift and tilt function	✓	
Fuel/water separator	✓		EH controls, joystick lift and tilt: – Additional integrated roller switches for 3 rd and 4 th functions		✓
Parking brake, disc and caliper	✓		EH controls, SAL 3 rd function: – Additional roller switch for 4 th function		✓
Precleaner, engine air intake	✓		EH parking brake	✓	
Radiator, high debris with wider fin spacing		✓	Ergonomic cab access ladders and handrails	✓	
Switch, transmission neutralizer lockout	✓		Filter, carbon fresh air		✓
Torque converter, locking clutch with free wheel stator	✓		Horn, electric	✓	
Transmission, automatic planetary power shift (4F/4R)	✓		Light, two dome (cab)	✓	
CAT® CONNECT TECHNOLOGIES			Mirrors, heated rearview external with integrated spot mirrors		✓
Detect technologies:			Mirrors, rearview external with integrated spot mirrors	✓	
Rear vision camera	✓		Multi-function 18 cm color touchscreen display for rear vision camera, clock and machine parameters	✓	
Cat rear object detection		✓	Post mounted membrane 16 switch keypad	✓	
Link technologies:			Precleaner, HVAC		✓
Product Link	✓		Precleaner, HVAC (RESPA)		✓
VIMS™		✓	Radio, AM/FM/CD/USB/MP3 Bluetooth®		✓
Payload technologies:		✓	Radio ready (entertainment) includes antenna, speakers and converter (12V, 10-amp)	✓	
Cat Production Measurement 2.0 (CPM), Printer, Cat Production Measurement, Aggregate Autodig			Receptacles (2), 12V	✓	
Advanced Productivity subscription		✓			
Machine security system		✓			

(continued on next page)

966M Wheel Loader Standard and Optional Equipment

Standard and Optional Equipment (continued)

Standard and optional equipment may vary. Consult your Cat dealer for details.

	Standard	Optional		Standard	Optional
OPERATOR ENVIRONMENT (continued)			ELECTRICAL AND LIGHTING (continued)		
Roof, metallic		✓	Work lights, two additional auxiliary front HI LED and two additional auxiliary rear LED cab-mounted, two LED work lights in the radiator grill, LED front turn signals, replacement of the standard four halogen cab mounted work lights with four LED work lights, LED roading lights		✓
Seat, cloth, air suspension	✓		Main disconnect switch	✓	
Seat, suede/cloth, air suspension, heated		✓	Receptacle start (cables not included)	✓	
Seat, leather/cloth, air suspension, heated/cooled		✓	Reversing strobes		✓
Seat belt, 51 mm retractable, with indicator	✓		Speed limiter – 20 km/h		✓
Seat belt, 4-point harness, with indicator		✓	Starter, electric, heavy duty	✓	
Steering, EH joystick, speed sensing with force feedback	✓		Starting and charging system (24V)	✓	
Steering, EH wheel with directional FNR shifter and gear selector: – Additional FNR with implement controls		✓	Secondary steering	✓	
Sun visor, front	✓		Speed limiter, adjustable	✓	
Sun visor, rear		✓	FLUIDS		
Viscous mounts	✓		Bio-degradable oil, Cat HYDO™		✓
Wet-arm wipers/washers front and rear, intermittent front wiper	✓		Premixed extended life coolant with freeze protection to -34°C	✓	
Windows, rubber mounted		✓	Premixed extended life coolant with freeze protection to -50°C		✓
Window, sliding (left and right sides)	✓		HYDRAULICS		
Windows, with front guard		✓	Hoses, Cat XT™	✓	
Windows, with heavy duty front guard		✓	Hydraulic oil cooler (swing-out)	✓	
Windows, with full guards front, rear and sides		✓	Hydraulic system, load sensing	✓	
ELECTRICAL AND LIGHTING			Oil sampling valves	✓	
Alarm, back-up	✓		3 rd function with Ride Control		✓
Alternator, 145-amp brushed	✓		4 th function with Ride Control		✓
Batteries (2), maintenance free 1,400 CCA	✓		Remote diagnostic pressure taps	✓	
Emergency engine shutdown switch	✓		Ride control, 2V	✓	
External seat belt indicator light		✓	Steering, load sensing	✓	
Ignition key: start/stop switch	✓		LINKAGE		
Lighting system: four halogen work lights (cab-mounted), two halogen roading lights (with signals), two halogen rear vision lights (hood-mounted), two rear LED position/stop/turn	✓		Forestry		✓
Work lights, four additional halogen cab-mounted or;		✓	High lift		✓
			Kickout, lift and tilt, automatic	✓	
			Quick coupler ready		✓
			Z-bar, cast crosstube/tilt lever	✓	
			STARTERS, BATTERIES, AND ALTERNATORS		
			Cold start – 240V		✓
			WORK TOOLS		
			Forks, logging		✓
			Forks, pallet		✓
			Fusion quick coupler		✓
			Performance Series buckets		✓

(continued on next page)

966M Wheel Loader Standard and Optional Equipment

Standard and Optional Equipment *(continued)*

Standard and optional equipment may vary. Consult your Cat dealer for details.

	Standard	Optional		Standard	Optional
COMPUTERIZED MONITORING SYSTEM			OTHER STANDARD AND OPTIONAL EQUIPMENT		
With following gauges:	✓		Auto idle shutdown	✓	
Speedometer/tachometer			Cat Autolube System		✓
Digital gear range indicator			Ecology drains for engine, transmission, and hydraulics	✓	
Diesel Exhaust Fluid (DEF) level			Ether aid ready	✓	
Temperature: engine coolant, hydraulic oil, transmission oil			Fenders, non-metallic front with mud-flap/rear with extension	✓	
Fuel level			Fenders, roading		✓
With following warning indicators:	✓		Filters: fuel, engine air, engine oil, hydraulic oil, transmission	✓	
Regeneration			Fuel cooler	✓	
Temperature: axle oil, engine intake manifold			Grease zerks	✓	
Pressure: engine oil, fuel pressure hi/low, primary steering oil, service brake oil			Grill, airborne debris	✓	
Battery voltage hi/low			Guard, power train		✓
Engine air filter restriction			Guard, rear radiator grill		✓
Hydraulic oil filter restriction			Hitch, drawbar with pin	✓	
Hydraulic oil low			Hood, non-metallic power tilting	✓	
Parking brake			Oil change, high-speed engine		✓
DEF low level			Platform, window washing	✓	
Transmission filter bypass			Precleaner, turbine		✓
			Precleaner, trash		✓
			Precleaner rain cap	✓	
			Service centers (electrical and hydraulic)	✓	
			Sight gauges: engine coolant, hydraulic oil, and transmission oil level	✓	
			Toolbox	✓	
			Vandalism protection caplocks	✓	
			Wheel chocks		✓
			OTHER CONFIGURATIONS		
			Aggregate handler		✓
			Industrial and waste handler		✓
			Forestry		✓

For more complete information on Cat products, dealer services, and industry solutions, visit us on the web at www.cat.com

Materials and specifications are subject to change without notice. Featured machines in photos may include additional equipment. See your Cat dealer for available options.

© 2018 Caterpillar. All Rights Reserved. CAT, CATERPILLAR, LET'S DO THE WORK, their respective logos, Cat Connect, Product Link, VIMS, XT, Fusion, HYDO, "Caterpillar Yellow", the "Power Edge" trade dress as well as corporate and product identity used herein, are trademarks of Caterpillar and may not be used without permission.

AEXQ2443-00 (11-2018)
2019 Product Update
Europe

